

Tyre Idler Pulleys

Tyre Idlers

Aetna rubber tire idlers share the same design advantages as standard Aetna idlers and are furnished with a SBR or EPDM rubber tires. They provide long life under demanding conditions and are installed with standard 1/2 or 5/8 bolts. Typically used in luggage handling carousels, belt conveyor systems and agricultural planters. They can be used as non-destructive belt tighteners to reduce wear on soft drive belts.

ADVANTAGES

- Over-size, factory packed lubricant chamber assures maximum life and operating efficiency without troublesome relubrication
- Bearing races are hardened to resist wear, outers and inners are accurately formed for smooth running
- Aetna's self-contouring, free-running, self-wiping seal provides positive contact under all conditions of misalignment
- Full ball complement for high durability

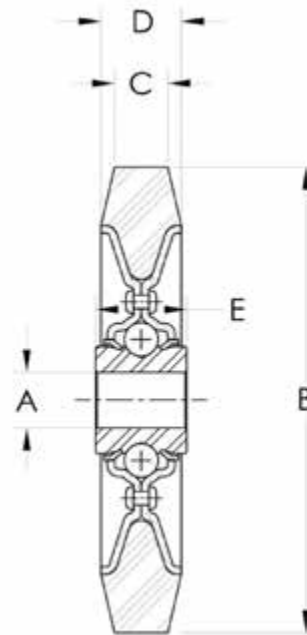
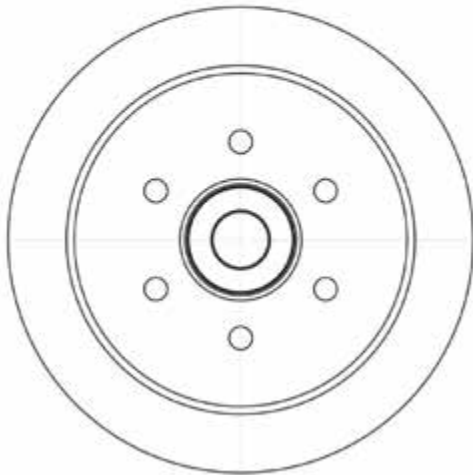

PART NO.	UNIT	BORE (A)	TYRE OD (B)	TYRE WIDTH (C)	OUTER WIDTH (D)	INNER WIDER (E)	WEIGHT (LBS / kg)
AG2341-ALS	Inch	.630/.636	4-1/4	19/32	7/8	13/16	.74
	mm	16.002/16.154	107.95	15.081	22.225	20.637	.335
AG2341-ALE	Inch	.630/.636	4-1/4	19/32	7/8	13/16	.74
	mm	16.002/16.154	107.95	15.081	22.225	20.637	.335
AG2342-A2T	Inch	.516/.522	4-1/4	19/32	7/8	13/16	.80
	mm	13.106/14.020	107.95	15.081	22.225	20.637	.362